

# WIERTNICA SAMOCHODOWA TYP H16S

## VEHICLE DRILLING RIG TYPE H16S

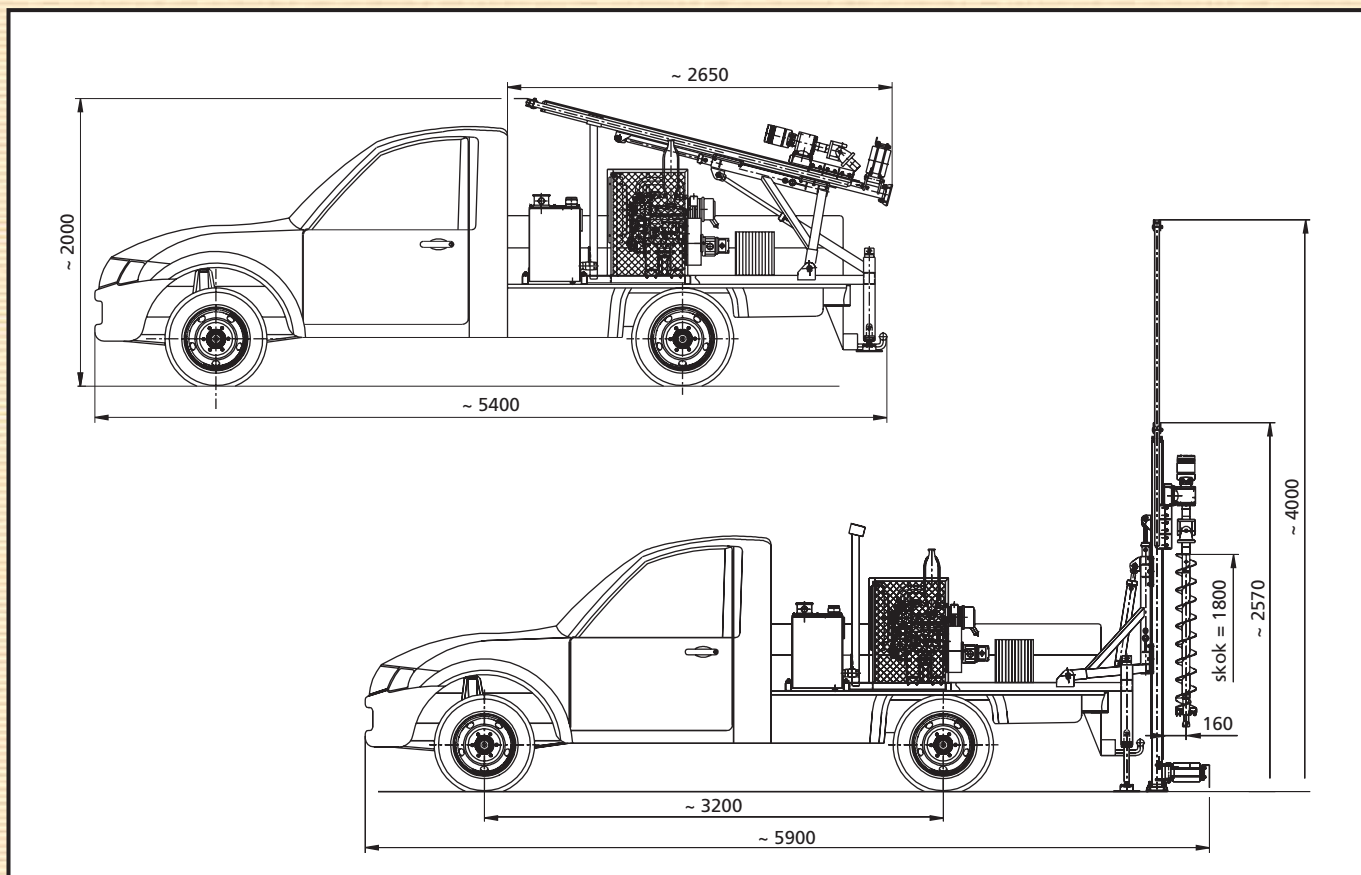

### DANE TECHNICZNE

Max. średnica wiercenia	Ø 160 mm	Ø 100 mm
Max. głębokość wiercenia	15 m	20 m
Głowica obrotowa		
moment obrotowy	950 Nm	
prędkość obrotowa	100 obr./min.	
Prowadnica		
max. siła docisku	12 kN	
siła wrywania	25 kN	
skok	1300 mm	
Napęd główny		
diesel lub benzyna		
moc	18 kW	
obroty max.	3000 obr./min.	
Układ hydrauliczny		
głowica obrotowa	42 dm <sup>3</sup> /min p = 20 MPa	
posuw głowicy	12 dm <sup>3</sup> /min p = 20 MPa	
Masa wiertnicy bez osprzętu (z olejem i paliwem)	650 kg	

### TECHNICAL SPECIFICATION

Max. drill diameter	Ø 160 mm	Ø 100 mm
Max. drill length	15 m	20 m
Rotary head		
torque	950 Nm	
revolutions	100 rpm	
max. down-force	12 kN	
pull out force	25 kN	
travel	1300 mm	
Main drive		
diesel or petrol		
power	18 kW	
rate of rotation	3000 rpm	
Hydraulic system		
rotary head	42 dm <sup>3</sup> /min p = 20 MPa	
head feed	12 dm <sup>3</sup> /min p = 20 MPa	
Rig weight without accessories (with oil and fuel)	650 kg	